

AUS Installation and Use Instructions

the devireg™ 610
10 Amp. Thermostat

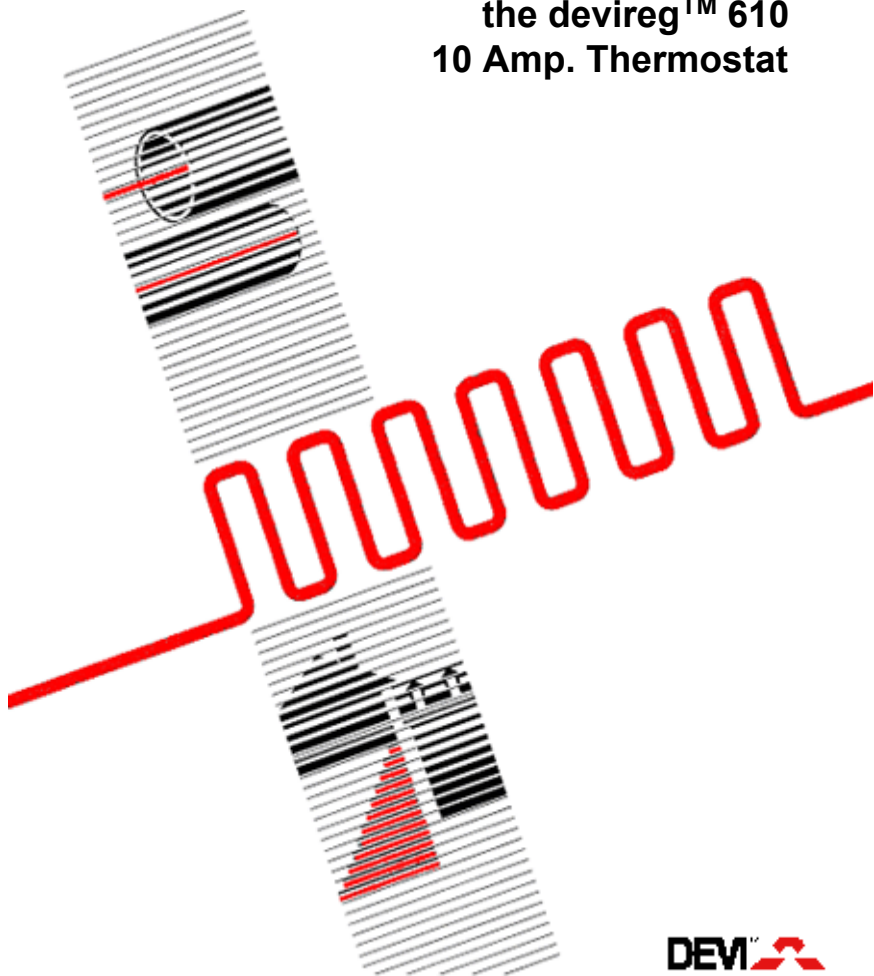

DEVI™ 

Application:

devireg™ 610 is an electronic thermostat designed for regulating heating and cooling, from -10°C to +50°C.

devireg™ 610 is moisture proof (IP44).

devireg™ 610 has a built-in 2-pole switch, so an external switch is not necessary.

devireg™ 610 is supplied with a NTC sensor of 2.5m cable. The sensing cable can be extended by up to 50m, using 1.5mm cable, without affecting the accuracy of the thermostat. However, the cable must not be placed parallel to high voltage cables. This is to prevent undesirable signals being induced. The installation must be permanent. The thermostat must be connected by a qualified electrician.

Installation:

1. Before opening the thermostat cover, set the adjustment button to the minimum temperature, 0°C.
2. When installing in bathrooms etc., a minimum distance to hazardous locations must be observed and must comply with current regulations for electric installations.
3. The stamped punchings for cable glands can be removed using a screwdriver and hammer.
4. The thermostat should be mounted vertically on a wall. The screw holes must be sealed with the enclosed plugs.
5. If the sensor is to be built-in or exposed to pressure it should be placed in a protective tube.
6. Wire connection according to circuit diagram, fig. 1 or 2. Select which function is required (Heating/Cooling).
7. After closing the thermostat cover, check that adjustment button can be adjusted within full temperature range, i.e. -10°C to +50°C.

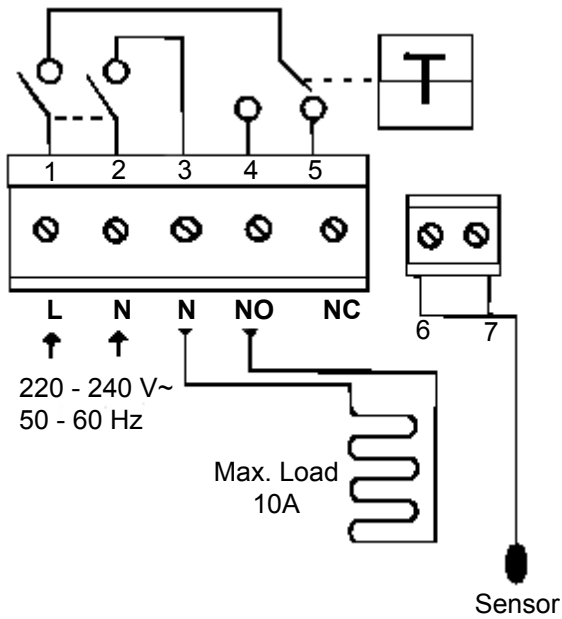

Fig. 1: Heating

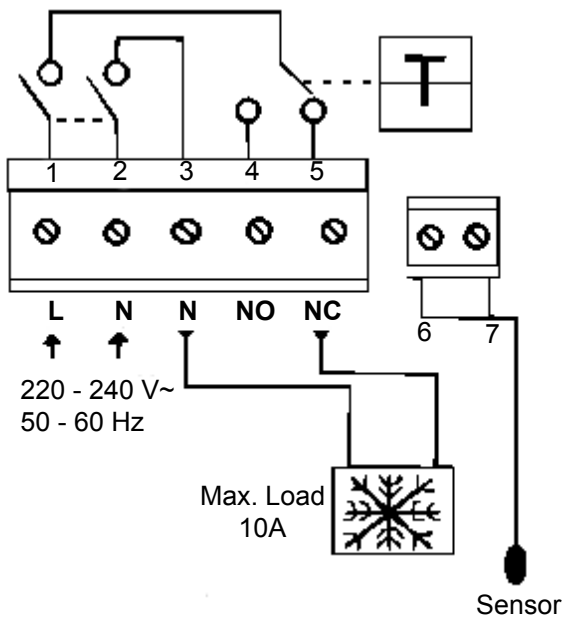

Fig. 2: Cooling

Trouble Shooting

If the thermostat is turned on but the heating is not on check all the circuit breakers, including the time switch, as well as the RCD. If these all seem to be in order, consult an authorised electrician and show them the following chart.

Trouble Shooting Chart

Reserved for the electrician!

1. Ensure that all the **terminal connections** are tight and check the voltage when the thermostat is activated.
2. Measure the **Floor Sensor** with an ohmmeter. It should give a certain resistance value in relation to the sensor's environment temperature (eg surrounding concrete) - see "Sensing Values" in the technical data chart.
3. Check the **Floor Sensor**. If the sensor wires, 6 & 7, are removed, the indicator should turn RED and the thermostat should switch ON. If not the thermostat is faulty.
4. Check the **Floor Sensor**. If the sensor wires, 6 & 7, are short circuited, the indicator should turn GREEN and the thermostat should switch OFF. If not the thermostat is faulty.
4. Test the **Heating Cable**. Check the installed wattage by measuring the voltage and the resistance and using them to calculate the output:

$$\begin{aligned} \text{KW} &= \frac{V^2}{R} / 1000 \\ &= \frac{57.6 \text{ (at 240 V~)}}{R} \end{aligned}$$

From the calculated output the heating cable type can be determined by looking it up in your DEVI catalogue.

Technical Data

Temperature Range:	-10°C to +50°C	
Operating Temp.	-30°C to +50°C	
Voltage:	220 to 240V ~ 50Hz	
Load:	10 (3) A	
Hysteresis:	0.4°C	
Moisture Proof:	IP 44	
Sensing Unit:	NTC	
Sensing Values:	-10°C	100kOhm
	0°C	50kOhm
	+25°C	15kOhm
	+50°C	5kOhm



Australian Warranty Certificate

The following Warranty is provided by DEVI Heating Systems ABN 39 898 434 262, hereinafter referred to as DEVI. It is offered in addition to any relevant statutory Federal or State Warranty.

DEVI is a partner of the DEVI Group of Companies, who are a Danish based specialist heating product manufacturer.

DEVI A/S Denmark is a member of the European Group of Suppliers, and is at all times subject to EEC general product liability rules.

DEVI warrants deviflex® heating cables for a period of TEN (10) YEARS from the date of purchase and all other DEVI products for a period of TWO (2) YEARS, from the date of purchase.

DEVI warrants its products against defects in manufacture, material, or workmanship. Proof of purchase must be provided. Installations must be carried out in accordance with the instructions supplied, and by accredited installers.

An authorized DEVI representative must be given the opportunity to inspect and report on any defects.

The obligation of DEVI, under this warranty, is to repair or replace any product, which, within the above stated time periods, is found to our satisfaction to be defective, free of charge to the customer. However, the labour cost for removing and/or refitting any product will be at the customer's expense. In the case of any removable products such as Thermostats, these are to be returned to the place of purchase, or to DEVI Sydney, where DEVI reserves the right to repair or replace the unit at no charge or unreasonable delay to the customer.

In case of parts not of our own manufacture you are entitled only to such benefits as we may receive under any guarantee given to us by the manufacturers in respect thereof. We shall not be liable for consequential or special damages under any circumstances whatsoever.

This Warranty does not cover faults caused by incorrect installation, damage by others, misuse, misapplication, incorrect voltage, lightning, or incorrect design by others, or where payment is in default. Rectification work, performed as a consequence of matters not covered by the Warranty, will be at the expense of the customer.

DEVI will respond honestly, efficiently and promptly to all queries and reasonable requests from our customers.

DEVI ABN 39 898 434 262

Head Office:

Tel: (02) 9997 2811

Fax: (02) 9997 7852

Freecall: 1 800 636 091

PO Box 707
MONA VALE
NSW 1660
Australia

WARRANTY AS SUPPLIED BY DEVI **DENMARK**

You have purchased a devireg™ 610 thermostat, which forms an integrated part of a deviheat system, which we are certain will improve your home comfort and economy. deviheat provides complete heating solutions with deviflex heating cables or devimat heating mats, devireg thermostats and devifast fitting bands.

If, however, contrary to all expectations, a problem should occur with your heating system, we at DEVI, with manufacturing units in Denmark, are, as European Union suppliers, subject to general product liability rules, as stated in Directive 85/374/GEE, and all relevant national laws which implies that: DEVI provides a warranty for deviflex heating cables and devimat heating mats for a 10 year period and all other DEVI products for 2 year period against defects in material and production.

The guarantee is granted on the condition that the WARRANTY CERTIFICATE on the overleaf is filled out properly in accordance to instructions and that the defect is inspected by, or presented to, DEVI or authorised DEVI distributor.

Please note that the wording of the WARRANTY CERTIFICATE must be provided in English or local language with the ISO code for your country in the upper left corner of the front page of the installation instructions in order to release the warranty.

The obligation of DEVI will be to repair or supply a new unit, free of charge to the customer, without secondary charges linked to repairing the unit. In case of defective devireg thermostats, DEVI reserves the right to repair the unit free of charge and without unreasonable delay to the customer.

The DEVI warranty does not cover installations made by unauthorised electricians, or faults caused by incorrect designs supplied by others, misuse, damage caused by others, or incorrect installation or any subsequent damage that may occur.

If DEVI is required to inspect or repair any defects caused by any of the above, then all work will be fully chargeable. The DEVI warranty is void, if payment of the equipment is in default. At all times, we at DEVI will respond honestly, efficiently and promptly to all queries and reasonable requests from our customers.

The above mentioned warranty concerns product liability whereas matters in relation to legislation on sale of goods shall be referred to national law.

*This Warranty is provided by DEVI A/S, Denmark.
Please contact your local DEVI Company for local
Warranty details

Warranty Certificate

The DEVI™ Warranty is granted to:

Name:

Address:

Postal Code:

Phone:

Please Observe!

In order to obtain the DEVI™ Warranty, the following must be carefully filled in. See other conditions on the overleaf.

Electrical Installation By:

Installation Date:

Type of Thermostat:

Production Code:

Suppliers Stamp



DEVI

DK . 7100 Vejle

Tif +45 76 42 47 00

Fax +45 76 42 47 03